

MEG alert™

Safety By Choice
Reliability By Design

Motor & Generator Protection

GP500/1000-MU-AS 1% Meter



MOTOR guard™

- AC Induction Motors
- AC Synchronous Motors
- DC Motors
- Wound Rotor Motors
- Servo Motors
- Submersible Motors



**Reduce Risk
to Save Lives**



Automatic Insulation Resistance Tester that monitors and protects critical-duty motors



Features: Model GP500-MU-AS/1000-MU-AS 1%

- Single Motor Model
- Auto/Manual test operation
- Adjustable alarm set point
- Adjustable pre-alarm set point
- Latching alarm contacts with manual reset
- Fused input and test output
- 500/1000 VDC test voltage
- Long-life, remote LED/switch assembly
- Compact, lightweight enclosure
- DIN Rail mounting bracket
- 1% Meg ohm meter with 4" color coded dial
- 10 Year Warranty

Optional Features

- EZ-Mount bracket for switch assembly
- 2% panel meter with color coded dial
- Digital meter with 4-20 mA output signal
- 4-20 mA transducer

SPECIFICATIONS: Model GP500-MU-AS/1000-MU-AS 1%

Input Voltage: 120 VAC, (optional 240 VAC), 50/60 Hz
 Input Current: .05 A max. @ 120 VAC
 Test Voltage: 500/1000 VDC @ 200 µA max.
 Maximum Line Voltage: 1000 V RMS
 Control Sensing: N/C Contact
 Alarm Time Delay: 0 - 10 Seconds
 Alarm/Lockout Contacts: 2 Form C, 5A @ 240 VAC or 28 VDC
 Pre-Alarm Contact: 1 Form C, 5A @ 240 VAC or 28 VDC
 LED Display: Power On: Green
 Test On: Yellow
 Pre-Alarm: Yellow Flashing
 Alarm: Red Flashing
 Meter Output: 1% Analog Signal
 Accuracy: 2% Overall
 Ambient Temperature: -20° F to 140° F
 Size: 2.75" H x 6" W x 4.5" D
 Weight: 1.5 lbs.
 Assembly: Meets UL 508/61010 specifications

Operation:

MotorGuard applies a current limited, fixed DC voltage to the motor windings during idle periods. A solid state comparator circuit monitors measured leakage current to the ground. Two adjustable set points, factory preset to customer specifications, can be programmed to signal a pre-alarm, alarm and lockout the equipment from operating if the low set point is exceeded. The manual reset feature enables a return to operational status only after the alarm condition has been corrected. MotorGuard will not impair normal operation of the equipment being monitored.

GP500-MU-AS

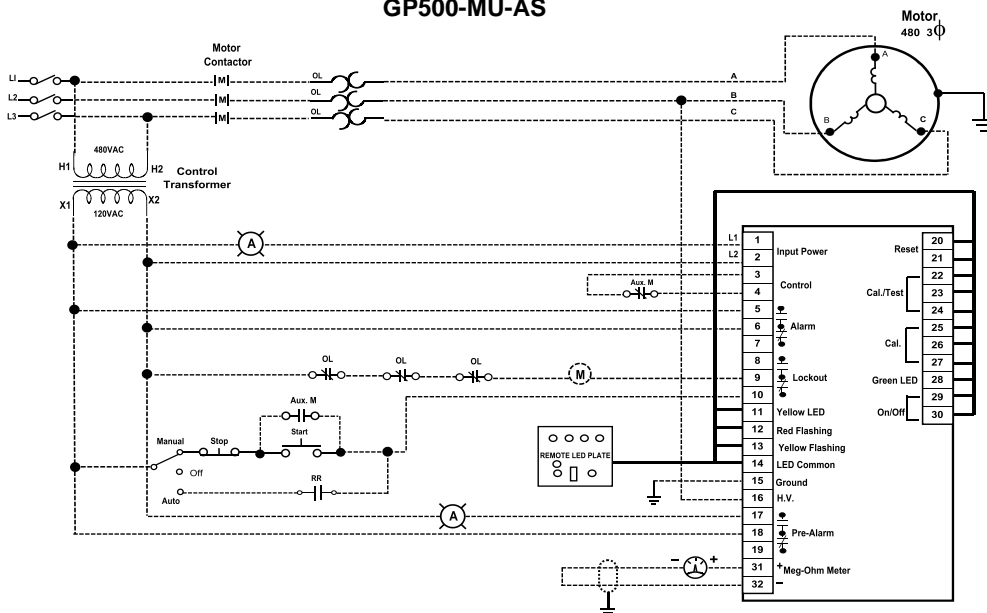

Typical Wiring Diagram

In addition to a wide variety of standard in-stock systems, our engineers will work with you on custom applications. Call the factory for details.

8766 Frank Drive
 Minocqua, WI 54548 USA
 715-356-1499
 sales@megalert.com
 service@megalert.com
 www.MegAlert.com
 U.S. Patents

9,664,716 – 9,977,067 – 10,782,357

<p>Meg-Alert, Inc. 715-356-1499</p>	<p>Legend</p> <p>RR Remote Start Relay</p> <p>⊕ Meg-Ohm Meter</p> <p>⊕ Remote Alarm</p> <p>M Motor Starter</p> <p>..... Customer Provided Wiring</p> <p>Shielded Wires</p>	<p>Drawn By: KM Delamater</p> <p>Checked: R. Zelm</p>	<p>GP500-MU-AS Typical Wiring Diagram</p>	<p>Date: 2/14/2020</p> <p>Scale: None</p>